

REVISIONS				
ZONE	REV.	DESCRIPTION	DATE	APPROVED
-	-	INITIAL RELEASE	1/13/2015	RC/CO

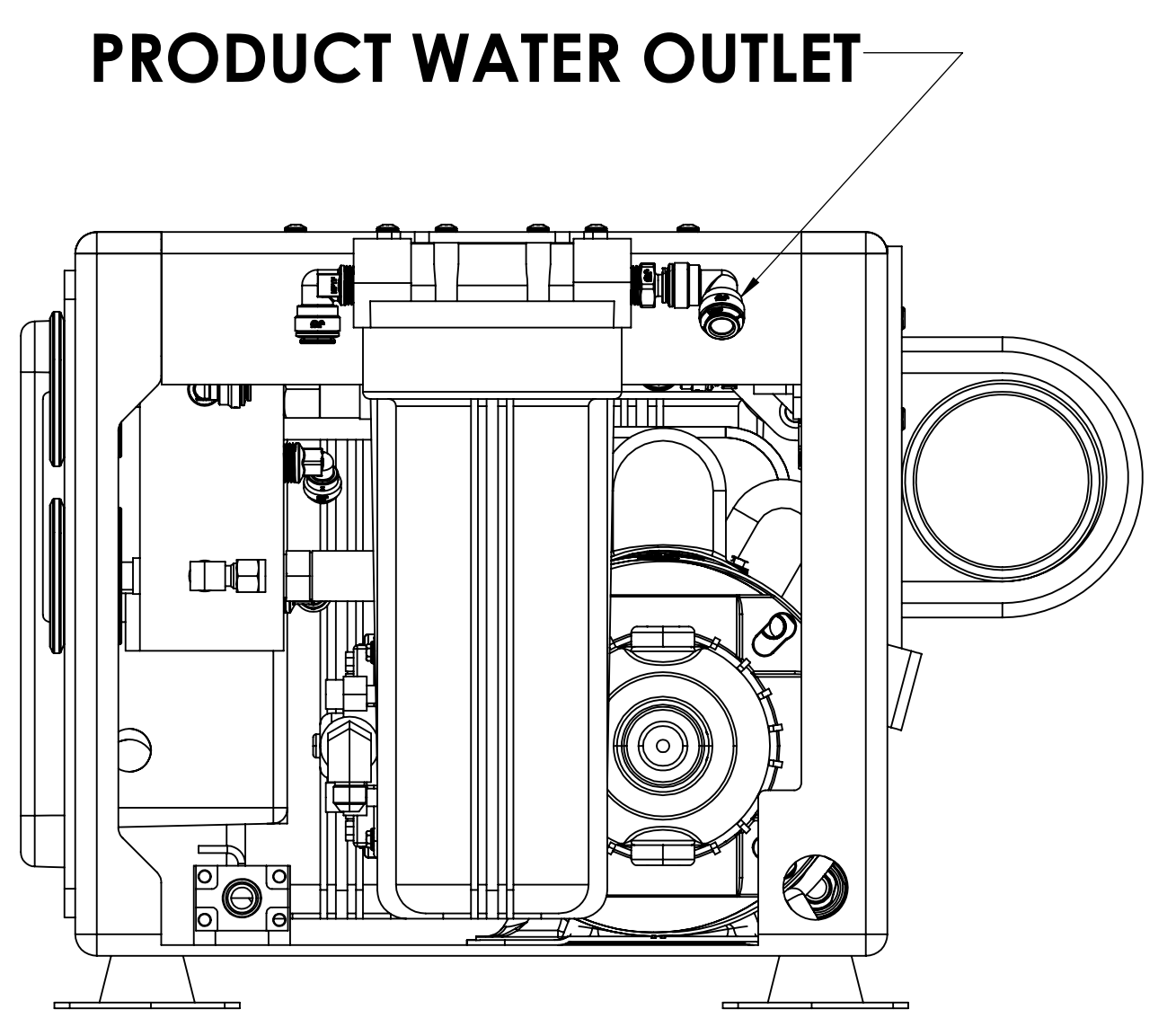
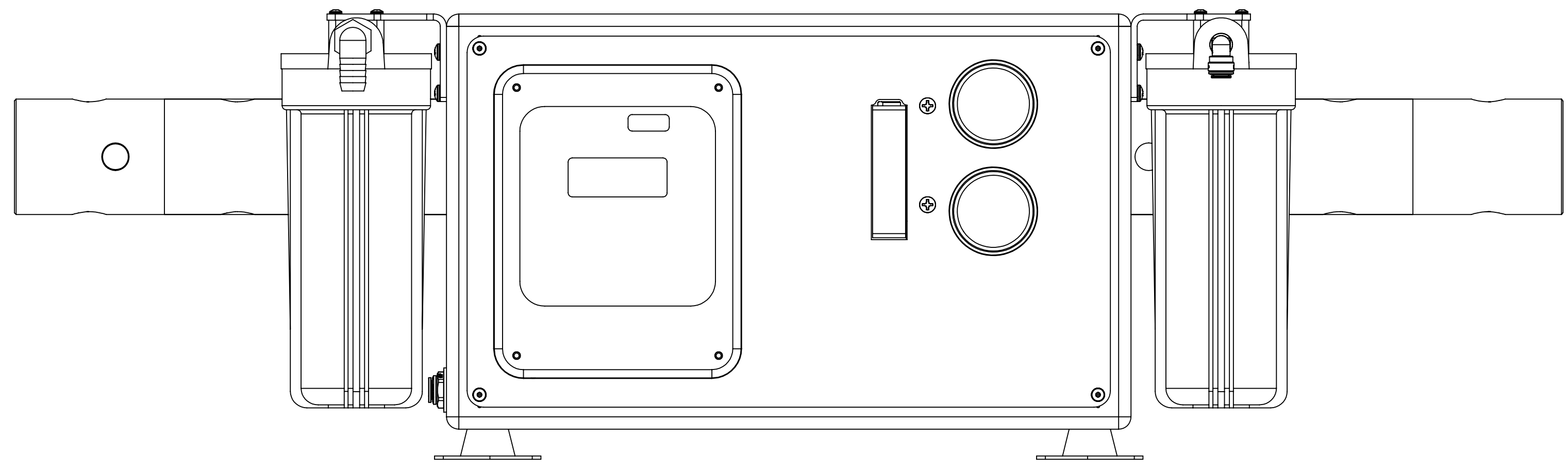
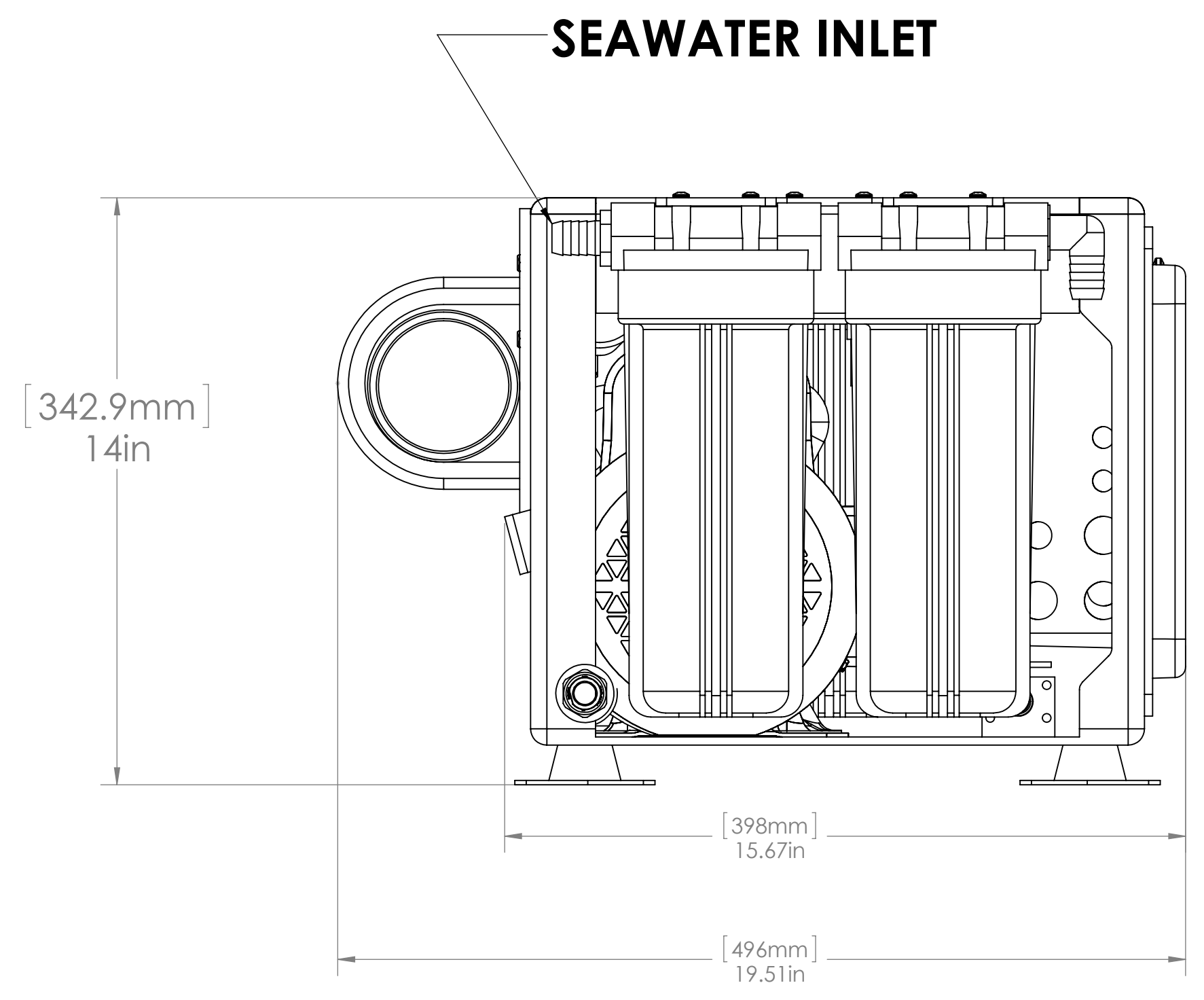
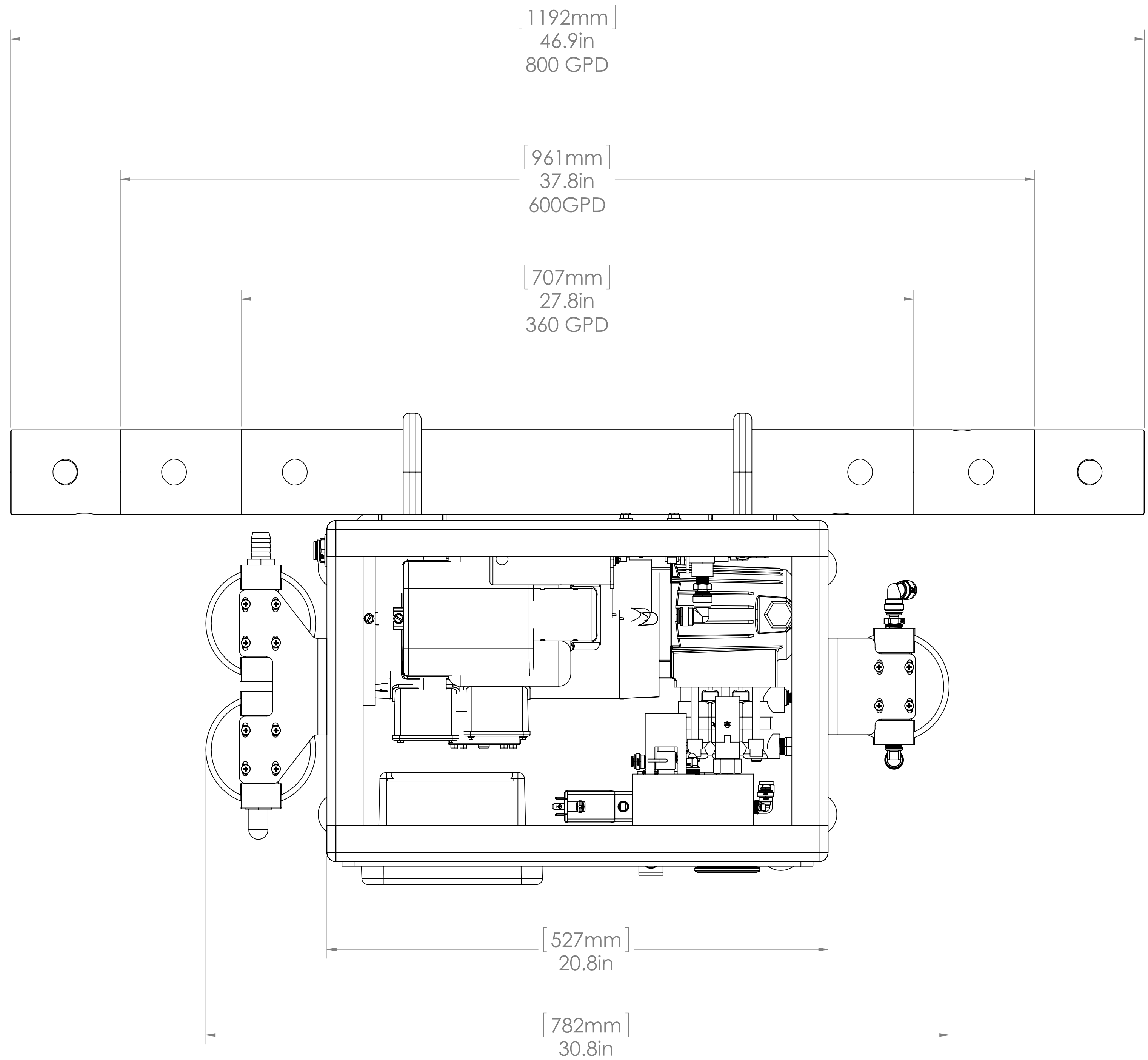

NOTICE OF CONFIDENTIALITY
THE INFORMATION CONTAINED IN THIS DRAWING IS THE SOLE PROPERTY OF BLUE WATER DESALINATION LLC. ANY REPRODUCTION, CIRCULATION, AND DISTRIBUTION IN PART OR AS A WHOLE WITHOUT THE WRITTEN CONSENT OF BLUE WATER DESALINATION LLC IS STRICTLY PROHIBITED.

Blue Water
DESALINATION LLC
1700 S. CALLE DEL SUR #100
CHULA VISTA, CA 92011
TEL: (619) 594-1474
FAX: (619) 594-1474
WWW.BLUEWATERDESALINATION.COM

ITEM: EXT1C - EXPRESS XT, COMPACT, AUTO

SCALE: 1:1 | **WEIGHT:** 100 LBS | **SHEET 1 OF 1**

REVISIONS:

NO.	DATE	DESCRIPTION
1	10/05/14	ISSUED FOR CONSTRUCTION
2	10/05/14	ISSUED FOR CONSTRUCTION
3	10/05/14	ISSUED FOR CONSTRUCTION
4	10/05/14	ISSUED FOR CONSTRUCTION

APPROVALS:

DESIGNED BY	CHECKED BY	DATE
DR	CR	10/05/14
DR	CR	10/05/14
DR	CR	10/05/14
DR	CR	10/05/14

MATERIAL: VARIOUS
FINISH: POWDER COAT
DO NOT SCALE DRAWING